

Datasheet

AC Control Tree for Daikin S21

Part No: 100597

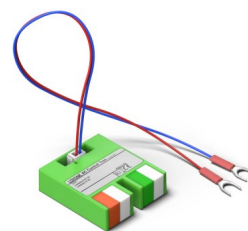

About the product

Seamlessly integrates Daikin S21 air conditioners into LOXONE – more comfort & over 30% less consumption through intelligent control.

Features:

- Plug & Play – commissioning in minutes, installation invisible inside the air conditioner
- Automatic heating and cooling with presence detection, window status and weather forecast – always the right temperature without manual intervention
- Automatically utilize PV surplus and spot prices
- Smart grid ready: gentle throttling instead of hard shutdown (compliant with Section 14a of the German Energy Industry Act)
- Controllable at any time via the LOXONE App or control elements including statistics functions and notifications

Electrical Specifications

Supply voltage	10 ... 30 V DC
Power consumption	typ. 0.1 W, max. 0.15 W

Interfaces

LOXONE Tree	Connection with Miniserver / Tree Extension
-------------	---

Ambient Conditions

Temperature	-20 ... 65°C / -4 ... 149°F
Humidity	max. 95 % RH (non-condensing)
Ingress protection	IP20

Connection Terminals

Terminal type	24 V DC & Loxone Tree
	DG220B
Wire cross-section	0.28 ... 0.8 mm ² / AWG 23 ... 18
Stripping length	5 ... 6 mm / 0.2 ... 0.24"
Temperature resistance	-40 ... 105 °C / -40 ... 221 °F

Connecting Cable

Wire cross-section	0.14 mm ² / AWG 26
Temperature resistance	80 °C / 176 °F
Length	300 mm / 11.81"
Part. No.	000582

Connection Diagram

Connection Diagram

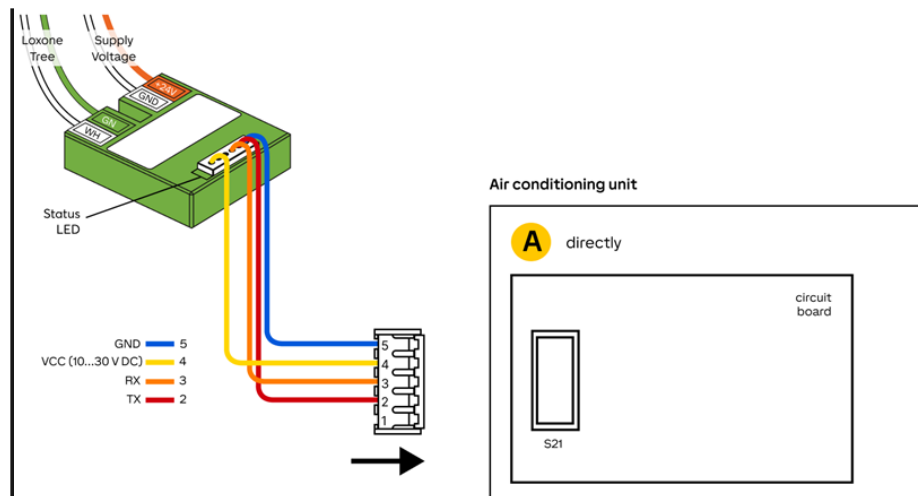

Product Characteristics

Colours	Green: RAL 6018
Finish	Matte

Weight & Dimensions

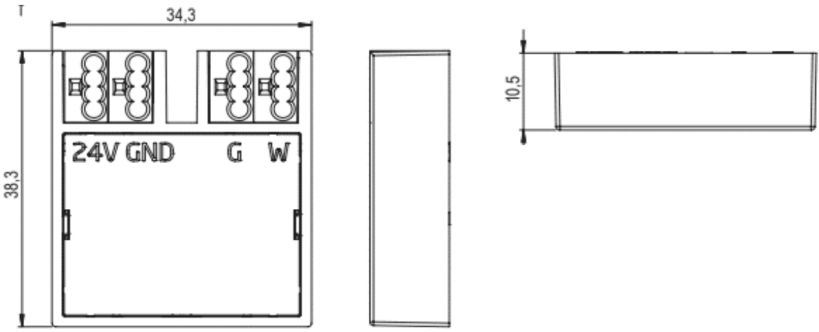
Net weight	57 g
Total weight	77 g
Product dimensions	38.3 x 34.3 x 10.5 mm / 1.50 x 1.35 x 0.41" (L x W x H)
Product dimensions drawing	
Pack size	79 x 79 x 41 mm / 3.11 x 3.11 x 1.61" (L x W x H)

Certifications & Standards



Installation must be carried out by a qualified electrician in accordance with the relevant regulations.

Published by

Loxone Electronics GmbH
Smart Home 1
4154 Kollerschlag
Austria
Tel: +43 7287 7070-0
loxone.com

Loxone UK Ltd.
The Forum
Station Road
Theale, RG7 4RA
United Kingdom

Datenblatt

AC Control Tree for Daikin S21

Part No: 100597

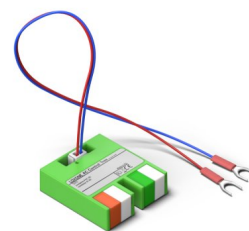

Über das Produkt

Bindet Daikin S21-Klimaanlagen nahtlos in LOXONE ein – mehr Komfort & über 30 % weniger Verbrauch durch intelligente Steuerung.

Features:

- Plug & Play – Inbetriebnahme in wenigen Minuten, Montage unsichtbar innerhalb der Klimaanlage
- Automatisches Heizen & Kühlen mit Präsenzerkennung, Fensterstatus und Wettervorhersage – immer die richtige Temperatur ohne manuelles Eingreifen
- PV-Überschuss und Spotpreise automatisch nutzen
- Smart-Grid-ready: sanftes Drosseln statt harter Abschaltung (§ 14a EnWG-konform)
- Bedienung jederzeit über die LOXONE App oder Bedienelemente inkl. Statistikfunktionen und Benachrichtigungen

Elektrische Spezifikationen

Versorgungsspannung	10 ... 30 V DC
---------------------	----------------

Leistungsaufnahme	typ. 0,1 W, max. 0,15 W
-------------------	-------------------------

Schnittstellen

LOXONE Tree	Verbindung mit Miniserver / Tree Extension
-------------	--

Umgebungsbedingungen

Temperatur	-20 ... 65°C / -4 ... 149°F
------------	-----------------------------

Luftfeuchtigkeit	max. 95 % r. F. (nicht kondensierend)
------------------	---------------------------------------

Schutzart	IP20
-----------	------

Anschlussklemmen

Klemmentyp	24 V DC & Loxone Tree
	DG220B
Leiterquerschnitt	0,28 ... 0,8 mm ² / AWG 23 ... 18
Abisolierlänge	5 ... 6 mm / 0,2 ... 0,24"
Temperaturbeständigkeit	-40 ... 105 °C / -40 ... 221 °F

Verbindungskabel

Leiterquerschnitt	0.14 mm ² / AWG 26
Temperaturbeständigkeit	80 °C / 176 °F
Länge	300 mm / 11,81"
Art. Nr.	000582

Anschlussplan

Anschlussplan

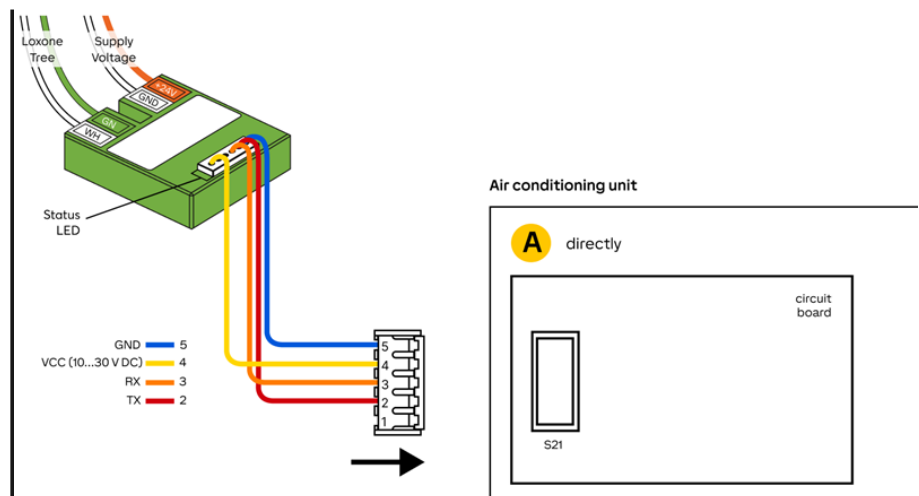

Produkteigenschaften

Farbe	Grün: RAL 6018
Glanzgrad	Matt

Gewicht & Abmessungen

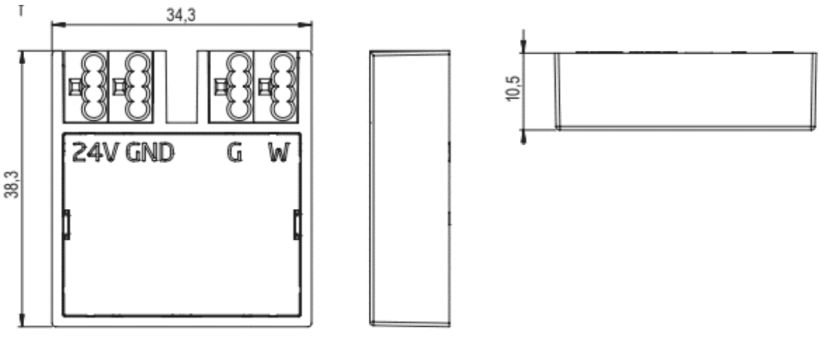
Nettogewicht	57 g
Bruttogewicht	77 g
Produktmaße	38,3 x 34,3 x 10,5 mm / 1,50 x 1,35 x 0,41" (L x B x H)
Produktmaßzeichnung	
Packmaß	79 x 79 x 41 mm / 3,11 x 3,11 x 1,61" (L x B x H)

Zertifizierungen & Standards



Die Installation muss von einer qualifizierten Elektrofachkraft gemäß den einschlägigen Vorschriften durchgeführt werden.

Veröffentlicht von

Loxone Electronics GmbH
Smart Home 1
4154 Kollerschlag
Austria
Tel: +43 7287 7070-0
loxone.com

Loxone UK Ltd.
The Forum
Station Road
Theale, RG7 4RA
United Kingdom